

IO-Link Gateway  
**UC2-IOL**

OPTEX FA CO. LTD.

The following operating procedure is for checking or changing setting values in a D3RF, D3WF, CDA, CD22 (via CDA) or TD1 (via CDA) connected to the UC2-IOL via IO-Link.

\* Refer to the UC2-IOL address list or the address list of the connected module being configured.

## General Description

IO-Link is used to connect the UC2-IOL to the IO-Link master unit, and a proprietary interface is used to connect the UC2-IOL to the connected modules (D3RF, etc.).

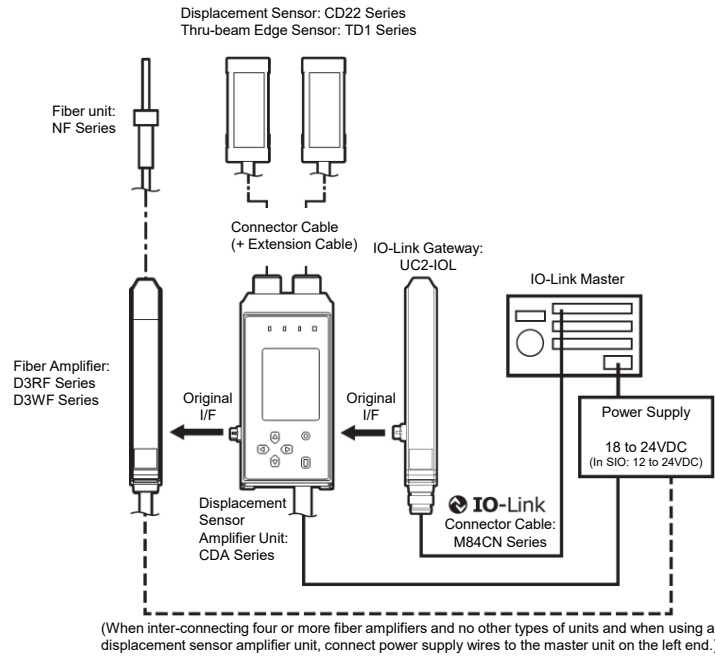

This means IO-Link should be used to check or change setting values in the connection module from the IO-Link master unit, and access should be through UC2-IOL module communication (address 262) and module data (address 263).

\* Refer to the UC2-IOL address list for more information on module communication (address 262) and module data (address 263).

\* Refer to the respective address list for the setting values and setting details of each connection module.

## Operating Procedure

1. Check the number of the module to check or change the setting value.

Check the number of the module for which the setting value will be checked or changed. The modules are numbered (1, 2, 3, etc.) according to their distance from the UC2-IOL, starting with the farthest (leftmost side).

Example: With 5 fiber amplifiers and 1 displacement sensor amplifier unit connected

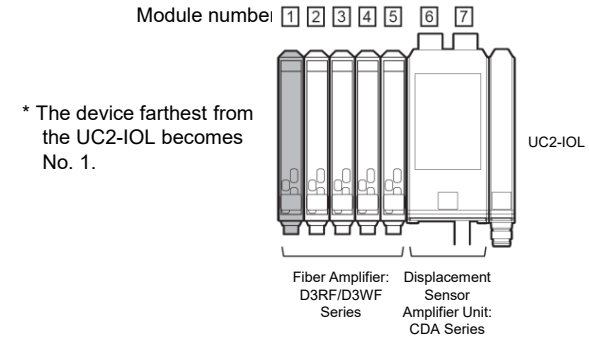

2. Check the module address and communication data length for the setting value to be checked or changed.

Refer to the address list of the module for which the setting value will be checked or changed, and check the module address and communication data length of the setting value.

Example:

To check the D3RF display setting	Module address: 100 Data length: 2
To perform D3WF first-point teaching	Module address: 202 Data length: 2
To check the CD22 near threshold	Module address: 130 Data length: 2

3. Set the module number, module address, and communication data length being checked or changed to the UC2-IOL. Configure the module number, module address, and communication data length in the UC2-IOL module communication settings (address: 262).

Example:

To check the display setting of the D3RF (Module number: 1)	Module number (address: 262, Sub-address: 1): 1 Module address (address: 262, Sub-address: 2): 100 Data length (address: 262, Sub-address: 3): 2
To perform first-point teaching for the D3WF (Module number: 2)	Module number (address: 262, Sub-address: 1): 2 Module address (address: 262, Sub-address: 2): 202 Data length (address: 262, Sub-address: 3): 2
To check the near threshold of the CD22 (Module number: 3)	Module number (address: 262, Sub-address: 1): 3 Module address (address: 262, Sub-address: 2): 130 Data length (address: 262, Sub-address: 3): 2





**INDEX LIST**

IO-Link GATEWAY

**UC2-IOL**

IO-Link setting file (IOPD file) can be downloaded from our web site.  
<https://www.optex-fa.com>

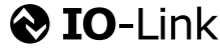

**OPTEX FA CO.,LTD.**

**Communication specifications**

<b>Min. cycle time</b>	2.2 ms	
<b>Baud rate</b>	COM3 (230.4kbps)	
<b>ISDU support</b>	Yes	
<b>IO-Link revision</b>	1.1	
<b>Inputting process data length</b>	32	
<b>Outputting process data length</b>	0	
<b>Vender ID</b>	dec: 1076	hex: 0x0434
<b>Device ID</b>	dec: 86017	hex: 0x15001

**Process Data Format**

**16 modules (13 analog outputs) (Index120: 0)**

Byte offset	0	1	2	3	4	5
Bit	7 6 5 4 3 2 1 0	7 6 5 4 3 2 1 0	7 6 5 4 3 2 1 0	7 6 5 4 3 2 1 0	7 6 5 4 3 2 1 0	7 6 5 4 3 2 1 0
Name	Analog output 1		Analog output 2		Analog output 3	

Byte offset	6	7	8	9	10	11
Bit	7 6 5 4 3 2 1 0	7 6 5 4 3 2 1 0	7 6 5 4 3 2 1 0	7 6 5 4 3 2 1 0	7 6 5 4 3 2 1 0	7 6 5 4 3 2 1 0
Name	Analog output 4		Analog output 5		Analog output 6	

Byte offset	12	13	14	15	16	17
Bit	7 6 5 4 3 2 1 0	7 6 5 4 3 2 1 0	7 6 5 4 3 2 1 0	7 6 5 4 3 2 1 0	7 6 5 4 3 2 1 0	7 6 5 4 3 2 1 0
Name	Analog output 7		Analog output 8		Analog output 9	

Byte offset	18	19	20	21	22	23
Bit	7 6 5 4 3 2 1 0	7 6 5 4 3 2 1 0	7 6 5 4 3 2 1 0	7 6 5 4 3 2 1 0	7 6 5 4 3 2 1 0	7 6 5 4 3 2 1 0
Name	Analog output 10		Analog output 11		Analog output 12	

Byte offset	24	25	26	27
Bit	7 6 5 4 3 2 1 0	7 6 5 4 3 2 1 0	7 6 5 4 3 2 1 0	7 6 5 4 3 2 1 0
Name	Analog output 13		Reserve	Reserve

Byte offset	28							
Bit	7	6	5	4	3	2	1	0
Name	Module 15 Output 2	Module 15 Output 1	Module 14 Output 2	Module 14 Output 1	Module 13 Output 2	Module 13 Output 1	Module 12 Output 2	Module 12 Output 1

Byte offset	29							
Bit	7	6	5	4	3	2	1	0
Name	Module 11 Output 2	Module 11 Output 1	Module 10 Output 2	Module 10 Output 1	Module 9 Output 2	Module 9 Output 1	Module 8 Output 2	Module 8 Output 1

Byte offset	30							
Bit	7	6	5	4	3	2	1	0
Name	Module 7 Output 2	Module 7 Output 1	Module 6 Output 2	Module 6 Output 1	Module 5 Output 2	Module 5 Output 1	Module 4 Output 2	Module 4 Output 1

Byte offset	31							
Bit	7	6	5	4	3	2	1	0
Name	Module 3 Output 2	Module 3 Output 1	Module 2 Output 2	Module 2 Output 1	Module 1 Output 2	Module 1 Output 1	Output 2	Output 1

**14 modules (14 analog outputs) (Index120: 1)**

Byte offset	0	1	2	3	4	5
Bit	7 6 5 4 3 2 1 0	7 6 5 4 3 2 1 0	7 6 5 4 3 2 1 0	7 6 5 4 3 2 1 0	7 6 5 4 3 2 1 0	7 6 5 4 3 2 1 0
Name	Analog output 1		Analog output 2		Analog output 3	

Byte offset	6	7	8	9	10	11
Bit	7 6 5 4 3 2 1 0	7 6 5 4 3 2 1 0	7 6 5 4 3 2 1 0	7 6 5 4 3 2 1 0	7 6 5 4 3 2 1 0	7 6 5 4 3 2 1 0
Name	Analog output 4		Analog output 5		Analog output 6	

Byte offset	12	13	14	15	16	17
Bit	7 6 5 4 3 2 1 0	7 6 5 4 3 2 1 0	7 6 5 4 3 2 1 0	7 6 5 4 3 2 1 0	7 6 5 4 3 2 1 0	7 6 5 4 3 2 1 0
Name	Analog output 7		Analog output 8		Analog output 9	

Byte offset	18	19	20	21	22	23
Bit	7 6 5 4 3 2 1 0	7 6 5 4 3 2 1 0	7 6 5 4 3 2 1 0	7 6 5 4 3 2 1 0	7 6 5 4 3 2 1 0	7 6 5 4 3 2 1 0
Name	Analog output 10		Analog output 11		Analog output 12	

Byte offset	24	25	26	27
Bit	7 6 5 4 3 2 1 0	7 6 5 4 3 2 1 0	7 6 5 4 3 2 1 0	7 6 5 4 3 2 1 0
Name	Analog output 13		Analog output 14	

Byte offset	28							
Bit	7	6	5	4	3	2	1	0
Name	Reserve		module 14 Output 2	module 14 Output 1	module 13 Output 2	module 13 Output 1	module 12 Output 2	module 12 Output 1

Byte offset	29							
Bit	7	6	5	4	3	2	1	0
Name	module 11 Output 2	module 11 Output 1	module 10 Output 2	module 10 Output 1	module 9 Output 2	module 9 Output 1	module 8 Output 2	module 8 Output 1

Byte offset	30							
Bit	7	6	5	4	3	2	1	0
Name	module 7 Output 2	module 7 Output 1	module 6 Output 2	module 6 Output 1	module 5 Output 2	module 5 Output 1	module 4 Output 2	module 4 Output 1

Byte offset	31							
Bit	7	6	5	4	3	2	1	0
Name	Module 3 Output 2	Module 3 Output 1	Module 2 Output 2	Module 2 Output 1	Module 1 Output 2	Module 1 Output 1	Output 2	Output 1

**16 modules (16 analog outputs) (Index120: 2)**

Byte offset	0	1	2	3	4	5
Bit	7 6 5 4 3 2 1 0	7 6 5 4 3 2 1 0	7 6 5 4 3 2 1 0	7 6 5 4 3 2 1 0	7 6 5 4 3 2 1 0	7 6 5 4 3 2 1 0
Name	Analog output 1		Analog output 2		Analog output 3	

Byte offset	6	7	8	9	10	11
Bit	7 6 5 4 3 2 1 0	7 6 5 4 3 2 1 0	7 6 5 4 3 2 1 0	7 6 5 4 3 2 1 0	7 6 5 4 3 2 1 0	7 6 5 4 3 2 1 0
Name	Analog output 4		Analog output 5		Analog output 6	

Byte offset	12	13	14	15	16	17
Bit	7 6 5 4 3 2 1 0	7 6 5 4 3 2 1 0	7 6 5 4 3 2 1 0	7 6 5 4 3 2 1 0	7 6 5 4 3 2 1 0	7 6 5 4 3 2 1 0
Name	Analog output 7		Analog output 8		Analog output 9	

Byte offset	18	19	20	21	22	23
Bit	7 6 5 4 3 2 1 0	7 6 5 4 3 2 1 0	7 6 5 4 3 2 1 0	7 6 5 4 3 2 1 0	7 6 5 4 3 2 1 0	7 6 5 4 3 2 1 0
Name	Analog output 10		Analog output 11		Analog output 12	

Byte offset	24	25	26	27	28	29
Bit	7 6 5 4 3 2 1 0	7 6 5 4 3 2 1 0	7 6 5 4 3 2 1 0	7 6 5 4 3 2 1 0	7 6 5 4 3 2 1 0	7 6 5 4 3 2 1 0
Name	Analog output 13		Analog output 14		Analog output 15	

Byte offset	30	31
Bit	7 6 5 4 3 2 1 0	7 6 5 4 3 2 1 0
Name	Analog output 16	

# Service Data

Index No. dec	hex	Sub-index No.	Name	Format (Offset)	Length	Access *1	Default value	Value/Range	Display *2
0	0x0	-	Direct Parameters 1	Record	16	R/W	-	-	
1	0x1	-	Direct Parameters 2	Record	16	R/W	-	-	
12	0xC	-	Device Lock	Record *3	2	R/W	-	-	
		2	Data Storage Lock	Bit(1)	1	R/W	0	0 : Unlock 1 : Lock	✓
16	0x10	-	Vendor Name	String	8	R	OPTEX FA	-	✓
18	0x12	-	Product Name	String	7	R	UC2-IOL	-	✓
19	0x13	-	Product ID	String	5	R	20366	-	✓
20	0x14	-	Product Text	String	45	R	Communication gateway	-	✓
21	0x15	-	Serial Number	String	12	R	-	-	✓
22	0x16	-	Hardware Version	String	4	R	-	-	✓
23	0x17	-	Firmware Version	String	19	R	-	-	✓
24	0x18	-	Application Specific Tag	String	32	R/W	*****	-	✓
36	0x24	-	Device Status	UInt	8	R	0	0 : Device is OK 4 : Failure	✓
37	0x25	-	Detailed Device Status	Array *3	15	R	-	-	
40	0x28	-	Process Data Input	PD In	16	R	-	-	
13	0xD	-	Profile characteristic	Array *3	8	R	-	-	
14	0xE	-	PDInput descriptor	Array *3	18	R	-	-	
15	0xF	-	PDOutput Descriptor	Array *3	3	R	-	-	
58	0x3A	-	Teach-in channel	UInt	8bit	R/W	1	0 = default Quint. = Module 1 Quint. 1 1 = Module 1 Quint. 1 2 = Module 1 Quint. 2 3 = Module 2 Quint. 1 4 = Module 2 Quint. 2 5 = Module 3 Quint. 1 6 = Module 3 Quint. 2 : 31 = Module 16 Quint. 1 32 = Module 16 Quint. 2 253 = All Quint. 1 254 = All Quint. 2	
59	0x3B	-	Teach-in state	Record *3	1	R	-	-	
		1	Teach flag SP2	Bit(6)	1bit	R	false	false = Not taught true = Successfully taught	
		2	Teach flag SP1	Bit(4)	1bit	R	false	false = Not taught true = Successfully taught	
		3	Teach state	Bit(0)	4bit	R	0	0 = IDLE 1 = SP1 SUCCESS 2 = SP2 SUCCESS 4 = WAIT FOR COMMAND 5 = BUSY 7 = ERROR	
64	0x40	-	Device / function name	String	32	R/W	*****	-	✓
67	0x43	-	Process data user definition	Record	7	R/W	-	-	
		1	User defined value for AO 1	Bit(104)	8bit	R/W	1	0 : No function / empty 1 : Current receiver level live Module 1 2 : Current receiver level live Module 2 3 : Current receiver level live Module 3 : 15 : Current receiver level live Module 15 16 : Current receiver level live Module 16	✓
		2	User defined value for AO 2	Bit(96)	8bit	R/W	2	Ditto	✓
		3	User defined value for AO 3	Bit(88)	8bit	R/W	3	Ditto	✓
		4	User defined value for AO 4	Bit(80)	8bit	R/W	4	Ditto	✓
		5	User defined value for AO 5	Bit(72)	8bit	R/W	5	Ditto	✓
		6	User defined value for AO 6	Bit(64)	8bit	R/W	6	Ditto	✓
		7	User defined value for AO 7	Bit(56)	8bit	R/W	7	Ditto	✓
		8	User defined value for AO 8	Bit(48)	8bit	R/W	8	Ditto	✓
		9	User defined value for AO 9	Bit(40)	8bit	R/W	9	Ditto	✓
		10	User defined value for AO 10	Bit(32)	8bit	R/W	10	Ditto	✓
		11	User defined value for AO 11	Bit(24)	8bit	R/W	11	Ditto	✓
		12	User defined value for AO 12	Bit(16)	8bit	R/W	12	Ditto	✓
		13	User defined value for AO 13	Bit(8)	8bit	R/W	13	Ditto	✓
		14	User defined value for AO 14	Bit(0)	8bit	R/W	14	Ditto	✓
120	0x78	-	Process data select	UInt	8bit	R/W	0	0 : 13 AO out of 16 modules 1 : 14 AO out of 14 modules 2 : 16 AO, no switching signals	✓
121	0x79	-	Pin 2 configuration	UInt	8bit	R/W	40	0 : Deactivated / no function 1 : External input (Smart Task) 17 : Teach-in 34 : Switching signal QL2 35 : Detection output Module 1 Quint. 1 36 : Detection output Module 1 Quint. 2 39 : Switching signal QL1 40 : Switching signal QL1/	✓
153	0x99	-	Temperature	Record *3	1	R	-	-	
		1	Current temperature	Bit(0)	8bit	R	-	-127...127 [°C]	✓
190	0xBE	-	Operating hours	Record *3	4	R	-	-	
		1	Total operating hours	Bit(0)	32bit	R	-	0...1000000 [h]	✓

Index No. dec	hex	Sub-index No.	Name	Format (Offset)	Length	Access *1	Default value	Value/Range	Display *2
204	0xCC	-	Find me	UInt	8bit	R/W	0	0 : Find me deactivated 1 : Find me activated	✓
219	0xDB	-	Article No. all components	Record	37	R	-	-	
		1	Article No. WI IO-Link Gateway	Bit(256)	5	R	20366	-	
		2	Article No. Module 1	Bit(240)	16bit	R	8449	8449 = D3RF (1 output) 8450 = D3RF (2 outputs) 8465 = D3WF (1 output) 8961 = CD22 (15mm model) on CDA 8962 = CD22 (35mm model) on CDA 8963 = CD22 (100mm model) on CDA 8993 = TD1 on CDA 9472 = Empty CDA channel 65535 = ERROR	
		3	Article No. Module 2	Bit(224)	16bit	R	8450	Ditto	
		4	Article No. Module 3	Bit(208)	16bit	R	8465	Ditto	
		5	Article No. Module 4	Bit(192)	16bit	R	8461	Ditto	
		6	Article No. Module 5	Bit(176)	16bit	R	8462	Ditto	
		7	Article No. Module 6	Bit(160)	16bit	R	8463	Ditto	
		8	Article No. Module 7	Bit(144)	16bit	R	8993	Ditto	
		9	Article No. Module 8	Bit(128)	16bit	R	---	Ditto	
		10	Article No. Module 9	Bit(112)	16bit	R	---	Ditto	
		11	Article No. Module 10	Bit(96)	16bit	R	---	Ditto	
		12	Article No. Module 11	Bit(80)	16bit	R	---	Ditto	
		13	Article No. Module 12	Bit(64)	16bit	R	---	Ditto	
		14	Article No. Module 13	Bit(48)	16bit	R	---	Ditto	
		15	Article No. Module 14	Bit(32)	16bit	R	---	Ditto	
		16	Article No. Module 15	Bit(16)	16bit	R	---	Ditto	
		17	Article No. Module 16	Bit(0)	16bit	R	---	Ditto	
226	0xE2	-	System state	Record *3	2	R	-	-	
		1	Input signal state Pin 2	Bit(7)	1bit	R	0	0 : External input LOW 1 : External input HIGH	✓
227	0xE3	-	Notification handling	UInt	8bit	R/W	0	0 : All enabled 1 : All disabled 2 : Events enabled, PD invalid flag disabled 3 : Events disabled, PD invalid flag enabled	✓
262	0x106	-	Module communication tunnel	Record	3	R/W	-	-	
		1	Module number	Bit(16)	8bit	R/W	1	1 : Module 1 2 : Module 2 3 : Module 3 : 15 : Module 15 16 : Module 16	
		2	Module index	Bit(8)	8bit	R/W	0	-	
		3	Data length	Bit(0)	8bit	R/W	0	0...32	
263	0x107	-	Module data	Record	35	R/W	-	-	
		1	Data	Bit(24)	32	R/W	-	-	
		2	Module Number Readback	Bit(16)	8bit	R	-	-	
		3	Module Index Readback	Bit(8)	8bit	R	-	-	
		4	Data Length Readback	Bit(0)	8bit	R	-	-	
269	0x10D	-	Module process data	Array	64	R	-	-	
270	0x10E	-	Module count	UInt	8bit	R	-	0...16	✓
1081	0x439	-	Input selector 1	UInt	8bit	R/W	0	0 : Module 1 Quint. 1 1 : Module 1 Quint. 2 2 : Module 2 Quint. 1 3 : Module 2 Quint. 2 4 : Module 3 Quint. 1 4 : Module 3 Quint. 1 : 30 : Module 16 Quint. 1 31 : Module 16 Quint. 2 64 : Ext.input 1	
1082	0x43A	-	Input selector 2	UInt	8bit	R/W	64	Ditto	
1083	0x43B	-	Logic 1	UInt	8bit	R/W	0	0 : DIRECT 1 : AND 2 : OR 3 : Window Mode 4 : Hysteresis	
1084	0x43C	-	Logic 2	UInt	8bit	R/W	0	Ditto	
1085	0x43D	-	Tiber 1 Mode	UInt	8bit	R/W	0	0 : deactivated 1 : T-on delay 2 : T-off delay 3 : T-on/T-off delay 4 : Impulse (one shot)	
1086	0x43E	-	Timer 2 Mode	UInt	8bit	R/W	0	Ditto	
1087	0x43F	-	Timer 1 Setup	UInt	16bit	R/W	1[ms]	1...30000 [ms]	
1088	0x440	-	Timer 2 Setup	UInt	16bit	R/W	1[ms]	1...30000 [ms]	
1089	0x441	-	Inverter 1	UInt	8bit	R/W	0	0 : not inverted 1 : inverted	
1090	0x442	-	Inverter 2	UInt	8bit	R/W	0	Ditto	
1093	0x445	-	Inverter Ext.input	UInt	8bit	R/W	0	Ditto	

\*1. R=Read only, R/W=Read/Write \*2. Supports the display function of OPTEX FA IO-Link master. \*3. No access to sub-index

# Events

Code	Name	Type	Description	
				dec
16912	0x4210	Device temperature over-run	Warning	Clear source of heat
16928	0x4220	Device temperature under-run	Warning	Insulate device
6144	0x1800	Short Circuit on Qx	Notification	Short circuit on outputs
6145	0x1801	Teach / value out of specified range	Notification	Teach / distance value out of specified range
6146	0x1802	Invalid module order	Error	Module 1...16 must follow the specified order (e.g. D3RF – D3WF – CDA)
6147	0x1803	Module count changed	Error	Module count has changed since last power-up of the gateway device.
6148	0x1804	Invalid module connected	Error	An invalid/not compatible module has been connected to the gateway.
6149	0x1805	Module communication fault	Notification	Fault detected in communication between modules

# Errors

Code	Additional code	Name	Description		
				dec	hex
128	0x80	17	0x11	Index not available	Access occurs to a not existing index
128	0x80	18	0x12	Subindex not available	Access occurs to a not existing subindex
128	0x80	32	0x20	Service temporarily not available	Parameter is not accessible due to the current state of the device application
128	0x80	35	0x23	Access denied	Write access on a read-only parameter
128	0x80	48	0x30	Parameter value out of range	Written parameter value is outside its permitted value range
128	0x80	51	0x33	Parameter length overrun	Written parameter length is above its predefined length
128	0x80	52	0x34	Parameter length underrun	Written parameter length is below its predefined length
128	0x80	64	0x40	Invalid parameter set	Written single parameter collides with other actual parameter settings
128	0x80	65	0x41	Inconsistent parameter set	Parameter inconsistencies were found at the end of block parameter transfer, device plausibility check failed

# System command

Index No. dec	hex	Sub-index No.	Access	Name	Value/Range	Display *2	Default value
2	0x2	-	W	System command	65: SP1 Teach 66: SP2 Teach 130: Restore Factory Settings		-

\*2. Supports the display function of OPTEX FA IO-Link master.

# OPTEX FA CO.,LTD.

[Headquarters]  
91 Chudoji-Awata-cho Shimogyo-ku Kyoto 600-8815 JAPAN  
TEL +81-75-325-1314 FAX +81-75-325-2936

<https://www.optex-fa.com>

Compact Laser Displacement Sensor

# CD22 Series

OPTEX FA CO. LTD.

## Module Address

Address No. Dec	hex	Name	Access *1	Format (Offset)	Length (Byte)	Value/Range	Address for CDA *2
1	0x1	Product Type	RO	UINT	2	0x0011	
2	0x2	Firmware Version	RO	UINT	2	0x0011	
3	0x3	Protocol Version	RO	UINT	2	0x0000	
4	0x4	Product Revision	RO	UINT	2	0x0000	
5	0x5	Vendor Name	RO	STRING	2 to 16	"OPTEX FA"	
6	0x6	Product Name	RO	STRING	2 to 32	Product name	
7	0x7	Product ID	RO	STRING	2 to 32	Product ID	
8	0x8	User Tag Name (Max. 32 bytes)	R/W	STRING	2 to 32	**	
9	0x9	Operation Status	RO	UINT	2	0: Initialize 1: Idle 2: Execute 3: For use by user	
98	0x62	Error Status Refer to the separate "Errors" table.	R/W	UINT	2	*Read: Last error code *Write arbitrary value: Delete last error code	
100	0x64	Threshold Near	R/W	UINT	2		✓
101	0x65	Threshold Far	R/W	UINT	2	-32768~32767	✓
102	0x66	Output hysteresis	R/W	UINT	2	0~32767	✓
103	0x67	Calculation flags	R/W	UINT	2	0: No calculation 1: With calculation	✓
104	0x68	Calculation coefficient Add (Setting value for each connected sensor)	R/W	UINT	2		✓
105	0x69	Calculation coefficient Multiply (Setting value for each connected sensor)	R/W	UINT	2	-10000~10000	✓
106	0x6A	Calculation coefficient Divide (Setting value for each connected sensor)	R/W	UINT	2	1~32767	✓
107	0x6B	Monitor Calculation Values	R/W	UINT	2	0: Sensor 2 measured value 1: Calculated value	✓
108	0x6C	Calculation Values Head1	R/W	UINT	2	0: None	✓
109	0x6D	Calculation Values Head2	R/W	UINT	2	1: Addition	✓
110	0x6E	Calculation Values Unit left Head1	R/W	UINT	2	2: Subtraction	✓
111	0x6F	Calculation Values Unit left Head2	R/W	UINT	2	3: Absolute value difference	✓
112	0x70	I/O polarity	R/W	UINT	2	0: PNP (N.O.) 1: NPN (N.O.) 2: PNP (N.C.) 3: NPN (N.C.)	✓
113	0x71	Output Selection CH1	R/W	UINT	2	0: No output 1: Calculated value within threshold range (GO) 2: Calculated value out of range on near side (LO) 3: Calculated value out of range on far side (HI)	✓
114	0x72	Output Selection CH2	R/W	UINT	2	4: Sensor 1 within threshold range (GO) 5: Sensor 1 out of range on near side (LO) 6: Sensor 1 out of range on far side (HI) 7: Sensor 2 within threshold range (GO) 8: Sensor 2 out of range on near side (LO) 9: Sensor 2 out of range on far side (HI)	✓
115	0x73	Output Selection CH3	R/W	UINT	2	0: No function 1: Teaching (Far side on rising edge, near side on falling edge) 2: BGS/FGS teaching 3: Zero reset 4: Laser emission OFF	✓
116	0x74	External input selection	R/W	UINT	2	0: None 1: Calculated value 2: Sensor 1 3: Sensor 2	✓
117	0x75	Analog output selection	R/W	UINT	2	0: No scaling 1: Scaling	✓
118	0x76	Analog scaling	R/W	UINT	2		✓
119	0x77	Analog Scaling (max.) 10 V / 20 mA	R/W	UINT	2		✓
120	0x78	Analog Scaling (min.) 0 V / 4 mA	R/W	UINT	2	-32768~32767	✓
121	0x79	Baud rate (Setting value for each connected sensor)	R/W	UINT	2	0: No connection 1: 9.6 kbps 2: 19.2 kbps 3: 38.4 kbps 4: 57.6 kbps 5: 115.2 kbps 6: 230.4 kbps 7: 312.5 kbps 8: 468.75 kbps 9: 600 kbps 10: 625 kbps 11: 833.3 kbps 12: 937.5 kbps 13: 1250 kbps	✓
129	0x81	Amplifier product code	RO	UINT	2	0x2932	✓
130	0x82	Switching point Near (Leap point Close)	R/W	UINT	2	CD22-15-485: -7499 to 7499 (in units of 1 μm)	
131	0x83	Switching point Far (Leap point Away)	R/W	UINT	2	CD22-35-485: -2249 to 2249 (in units of 10 μm)	
132	0x84	Background ObSB	R/W	UINT	2	CD22-100-485: -7499 to 7499 (in units of 1 μm)	
133	0x85	Tolerance ObSB	R/W	UINT	2	CD22-15-485: 0 to 7499 (in units of 1 μm) CD22-35-485: 0 to 2249 (in units of 10 μm) CD22-100-485: 0 to 7499 (in units of 1 μm)	

Address No. dec	hex	Name	Access *1	Format (Offset)	Length (Byte)	Value/Range	Address for CDA *2
134	0x86	Average Number	R/W	UINT	2	0: 1 time 1: 8 times 2: 64 times 3: 512 times	
135	0x87	Teaching mode	R/W	UINT	2	0: 2-point teaching 1: 1-point teaching 2: FGS2	
136	0x88	Sampling rate	R/W	UINT	2	0: 500 μs 1: 1ms 2: 2ms 3: 4ms 4: AUTO	
137	0x89	Keylock	R/W	UINT	2	0: No locking 1: Locking	
138	0x8A	Switching behavior	R/W	UINT	2	0: Light ON (ON within range) 1: Dark ON (ON outside of range)	
139	0x8B	Calibration distance Close	R/W	UINT	2	CD22-15-485: -7499 to 7499 (in units of 1 μm) CD22-35-485: -2249 to 2249 (in units of 10 μm) CD22-100-485: -7499 to 7499 (in units of 1 μm)	
140	0x8C	Calibration distance Away	R/W	UINT	2		
141	0x8D	Error Behavior	R/W	UINT	2	0: Output clamp error value (H7FFF) 1: Maintain the effective measured value immediately before hold	
142	0x8E	Clamp holding time	R/W	UINT	2	0~9999	
144	0x90	Zeroing Value	RO	UINT	2	CD22-15-485: -7499 to 7499 (in units of 1 μm) CD22-35-485: -2249 to 2249 (in units of 10 μm) CD22-100-485: -7499 to 7499 (in units of 1 μm)	
148	0x94	Barycenter	R/W	UINT	2	0: Waveform with highest received light level 1: Point closest to sensor 2: Second-closest point to sensor 3: Third-closest point to sensor 4: Fourth-closest point to sensor 5: Fifth-closest point to sensor	
151	0x97	Hysteresis value	R/W	UINT	2	CD22-15-485: 0 to 7499 (in units of 1 μm) CD22-35-485: 0 to 2249 (in units of 10 μm) CD22-100-485: 0 to 7499 (in units of 1 μm)	
152	0x98	Sensitivity	R/W	UINT	2	0: Automatic adjustment 1: Lowest 2: Low 3: Medium 4: Medium-high 5: High 6: Highest	
153	0x99	Light threshold	R/W	UINT	2	0: Lowest surface 1: Low position 2: Middle position 3: High position	
155	0x9B	Keylock active	R/W	UINT	2	0: Display when locked 1: Off when locked	
200	0xC8	Save Zero Reposition	WO	Byte	2	Execute with written value	
201	0xC9	Cancel zero-reset	WO	Byte	2	Execute with written value	
202	0xCA	Teach in 1 Point	WO	UINT	2	Execute with written value	
203	0xCB	Teach in 2 Point	WO	UINT	2	Execute with written value	
204	0xCC	Teach in ObsB	WO	UINT	2	Execute with written value	
210	0xD2	Warm start Reset	WO	UINT	2	3: Restart	
211	0xD3	Return to top menu	WO	Byte	2	0, 1, 2: Execute	
212	0xD4	Factory Reset	WO	UINT	2	3: Initialize	

\*1. RO=Read Only, R/W=Read/Write, WO=Write Only  
\*2. Displacement Sensor Amplifier Unit

## Errors

High-order byte		Low-order byte		Description
dec	hex	dec	hex	
0	0x0	0	0x0	No error
Applicable address number		1	0x1	The address number is out of range.
		2	0x2	The sub address number is not supported.
		3	0x3	The ETX code in the command string is invalid.
		4	0x4	A checksum error was detected.
		5	0x5	The command code is invalid.
		6	0x6	A non-regulated parameter was specified.
		7	0x7	An out of range numeric value was specified.
		8	0x8	Reserved
		9	0x9	

**OPTEX FA CO., LTD.**

[Headquarters]

91 Chudoji-Awata-cho Shimogyo-ku Kyoto 600-8815  
JAPAN

TEL +81-75-325-1314 FAX +81-75-325-2936

<https://www.optex-fa.com>

Displacement Sensor Amplifier Unit

# CDA Series

**OPTEX FA CO. LTD.**

## Module Address

Address No.		Name	Access*	Format (Offset)	Length (Byte)	Value/Range
dec	hex					
100	0x64	Threshold Near	R/W	UINT	2	
101	0x65	Threshold Far	R/W	UINT	2	-32768~32767
102	0x66	Output hysteresis	R/W	UINT	2	0~32767
103	0x67	Calculation flags	R/W	UINT	2	0: No calculation 1: With calculation
104	0x68	Calculation coefficient Add (Setting value for each connected sensor)	R/W	UINT	2	
105	0x69	Calculation coefficient Multiply (Setting value for each connected sensor)	R/W	UINT	2	-10000~10000
106	0x6A	Calculation coefficient Divide (Setting value for each connected sensor)	R/W	UINT	2	1~32767
107	0x6B	Monitor Calculation Values	R/W	UINT	2	0: Sensor 2 measured value 1: Calculated value
108	0x6C	Calculation Values Head1	R/W	UINT	2	0: None
109	0x6D	Calculation Values Head2	R/W	UINT	2	1: Addition
110	0x6E	Calculation Values Unit left Head1	R/W	UINT	2	2: Subtraction
111	0x6F	Calculation Values Unit left Head2	R/W	UINT	2	3: Absolute value difference
112	0x70	I/O polarity	R/W	UINT	2	0: PNP (N.O.) 1: NPN (N.O.) 2: PNP (N.C.) 3: NPN (N.C.)
113	0x71	Output Selection CH1	R/W	UINT	2	0: No output 1: Calculated value within threshold range (GO)
114	0x72	Output Selection CH2	R/W	UINT	2	2: Calculated value out of range on near side (LO) 3: Calculated value out of range on far side (HI)
115	0x73	Output Selection CH3	R/W	UINT	2	4: Sensor 1 within threshold range (GO) 5: Sensor 1 out of range on near side (LO) 6: Sensor 1 out of range on far side (HI) 7: Sensor 2 within threshold range (GO) 8: Sensor 2 out of range on near side (LO) 9: Sensor 2 out of range on far side (HI)
116	0x74	External input selection	R/W	UINT	2	0: No function 1: Teaching (Far side on rising edge, near side on falling edge) 2: BGS/FGS teaching 3: Zero reset 4: Laser emission OFF
117	0x75	Analog output selection	R/W	UINT	2	0: None 1: Calculated value 2: Sensor 1 3: Sensor 2
118	0x76	Analog scaling	R/W	UINT	2	0: No scaling 1: Scaling
119	0x77	Analog Scaling (max.) 10 V /20 mA	R/W	UINT	2	
120	0x78	Analog Scaling (min.) 0 V / 4 mA	R/W	UINT	2	-32768~32767
121	0x79	Baud rate (Setting value for each connected sensor)	R/W	UINT	2	0: No connection 1: 9.6 kbps 2: 19.2 kbps 3: 38.4 kbps 4: 57.6 kbps 5: 115.2 kbps 6: 230.4 kbps 7: 312.5 kbps 8: 468.75 kbps 9: 500 kbps 10: 625 kbps 11: 833.3 kbps 12: 937.5 kbps 13: 1250 kbps
129	0x81	Amplifier product code	RO	UINT	2	0x2503

**OPTEX FA CO., LTD.**

[Headquarters]

91 Chudoji-Awata-cho Shimogyo-ku Kyoto 600-8815  
JAPAN

TEL +81-75-325-1314 FAX +81-75-325-2936

<https://www.optex-fa.com>

\* RO=Read Only, R/W=ReadWrite, WO=Write Only

Digital Fiber Amplifier

# D3RF Series

**OPTEX FA CO. LTD.**

## Module Address

Address No.		Name	Access*	Format (Offset)	Length (Byte)	Value/Range
dec	hex					
1	0x1	Product Type	RO	UINT	2	0x0012
2	0x2	Firmware Version	RO	UINT	2	0x0200 or more
3	0x3	Protocol Version	RO	UINT	2	0x0001
4	0x4	Product Revision	RO	UINT	2	0x0001
5	0x5	Vendor Name	RO	STRING	2 to 16	"OPTEX FA"
6	0x6	Product Name	RO	STRING	2 to 32	Product name
7	0x7	Product ID	RO	STRING	2 to 16	Product ID
8	0x8	User Tag Name (Max. 32 bytes)	R/W	STRING	2 to 32	**
9	0x9	Operation Status	RO	UINT	2	0: Initialize 1: Idle 2: Execute 3: For use by user
98	0x62	Error Code Refer to the separate "Errors" table.	R/W	UINT	2	• Read: Last error code • Write arbitrary value: Delete last error code
100	0x64	Display	R/W	UINT	2	0: Numeric display 1: Bar display 2: Percentage display
102	0x66	Teach-in mode CH1	R/W	UINT	2	0: 2-point teaching 1: 1-point teaching 2: Through teaching 3: Zone teaching
103	0x67	Teach-in mode CH2	R/W	UINT	2	4: Auto-teaching 5: Percent teaching 6: Zero percent teaching
104	0x68	Response Speed	R/W	UINT	2	0: 1-HS (22 μs) 1: 2-FS (85 μs) 2: 3-ST (250 μs) 3: 4-LG (1 ms) 4: 5-PL (2 ms) 5: 6-UL (4 ms) 6: 7-EL (8 ms)
105	0x69	Gain	R/W	UINT	2	0: Low power 1: Medium power 2: High power
106	0x6A	MF-Input	R/W	UINT	2	0: External teaching input 1: Test input 2: Synchronous input 3: Counter reset input 4: External all teaching input 5: No function
107	0x6B	Key Lock	R/W	UINT	2	0: Unlock 1: Lock level 1 (Full lock) 2: Lock level 2 (Half lock)
108	0x6C	Operation mode CH1	R/W	UINT	2	0: L-on (Light ON)
109	0x6D	Operation mode CH2	R/W	UINT	2	1: D-on (Dark ON)
110	0x6E	Threshold level CH1 Lower Limit	R/W	UINT	2	-999 to 9999 The writable range varies depending on the operation mode.
111	0x6F	Threshold level CH1 Upper Limit	R/W	UINT	2	-999 to 9999 Accessible only in Zone teaching mode.
112	0x70	Threshold level CH2 Lower Limit	R/W	UINT	2	-999 to 9999 The writable range varies depending on the operation mode.
113	0x71	Threshold level CH2 Upper Limit	R/W	UINT	2	-999 to 9999 Accessible only in Zone teaching mode.

Address No.		Name	Access*	Format (Offset)	Length (Byte)	Value/Range
dec	hex					
114	0x72	Timer setting CH1	R/W	UINT	2	0: OFF delay timer
115	0x73	Timer setting CH2	R/W	UINT	2	1: One-shot timer
116	0x74	CH1 Off delay time	R/W	UINT	2	
117	0x75	CH1 On delay time	R/W	UINT	2	0~9999: 0~9999ms
118	0x76	CH2 Off delay time	R/W	UINT	2	-1~-9: 0.1~0.9ms
119	0x77	CH2 On delay time	R/W	UINT	2	
123	0x7B	Hysteresis	R/W	UINT	2	1~40
125	0x7D	ASC (Automatic Sensitivity Control)	R/W	UINT	2	0: None 1: Normal correction 2: High-speed correction 3: Max. speed correction
126	0x7E	Energy Saving	R/W	UINT	2	0: Standard 1: Turn off display automatically 2: Emission cycle x 2 3: Display and emission cycle
127	0x7F	Reverse display	R/W	UINT	2	0: Standard 1: Inverted display
200	0xC8	Store zero-reset	WO	Byte	2	0 to 65535: Execute
201	0xC9	Cancel zero-reset	WO	Byte	2	0 to 65535: Execute
202	0xCA	Teach-in 1-point	WO	UINT	2	1: Output 1 teaching
203	0xCB	Teach-in 2-point	WO	UINT	2	2: Output 2 teaching
210	0xD2	Warm start Reset	WO	UINT	2	3: Restart
211	0xD3	Return to top menu	WO	Byte	2	Execute with written value
212	0xD4	Factory Reset	WO	UINT	2	3: Initialize (Allowed only when unlocked)

\* RO=Read Only, R/W=Read/Write, WO=Write Only

## Errors

High-order byte		Low-order byte		Description
dec	hex	dec	hex	
0	0x0	0	0x0	No error
Applicable address number		1	0x1	The address number is out of range.
		2	0x2	The sub address number is not supported.
0	0x0	3	0x3	An attempt was made to write setting values to sensors that are all locked, or to initialize while locked.
		4	0x4	The teaching target output specification value (1 or 2) is incorrect.
		5	0x5	Teaching mode has no second teaching, or the first has not yet been executed.
		6	0x6	The execution specification value (3) for restart and initialization is incorrect.
Applicable address number		7	0x7	An attempt was made to write a setting value that is out of range.
		8	0x8	The setting value write operation failed. (Attempted to write a read-only setting value)
0	0x0	9	0x9	Teaching to output 2 was attempted while output 2 was in counter mode.
		11	0xB	The amount of light received during teaching was too low.
		12	0xC	The amount of light received during teaching was saturated.
		13	0xD	There was too little difference in the amount of light received during 2-point teaching.
		14	0xE	A teaching operation other than auto-teaching was attempted in differential operation mode.
		15	0xF	A hardware error was detected.

**OPTEX FA CO., LTD.**

[Headquarters]

91 Chudoji-Awata-cho Shimogyo-ku Kyoto 600-8815  
JAPAN

TEL +81-75-325-1314 FAX +81-75-325-2936

<https://www.optex-fa.com>

White LED Digital Fiber Amplifier

# D3WF Series

OPTEX FA CO. LTD.

## Module Address

Address No.		Name	Access*	Format (Offset)	Length (Byte)	Value/Range
dec	hex					
1	0x1	Product Type	RO	UINT	2	0x0012
2	0x2	Firmware Version	RO	UINT	2	0x0100
3	0x3	Protocol Version	RO	UINT	2	0x0001
4	0x4	Product Revision	RO	UINT	2	0x0001
5	0x5	Vendor Name	RO	STRING	2 to 16	"OPTEX FA"
6	0x6	Product Name	RO	STRING	2 to 32	Product name
7	0x7	Product ID	RO	STRING	2 to 16	Product ID
8	0x8	User Tag Name (Max. 32 bytes)	R/W	STRING	2 to 32	User ID (Max. 32 characters)
9	0x9	Operation Status	RO	UINT	2	0: Initialize 1: Idle 2: Execute 3: For use by user
98	0x62	Error Code Refer to the separate "Errors" table.	R/W	UINT	2	• Read: Last error code • Write arbitrary value: Delete last error code
100	0x64	Display	R/W	UINT	2	0: Numeric display 1: Bar display 2: Percentage display
102	0x66	Teach-in mode CH1	R/W	UINT	2	0: 1-point teaching 1: 2-point teaching
103	0x67	Teach-in mode CH2	R/W	UINT	2	2: Dynamic teaching
104	0x68	Response speed	R/W	UINT	2	0: 16 μs 1: 200 μs
105	0x69	Gain	R/W	UINT	2	0: Low power 1: Standard power 2: High power 3: Automatic power
106	0x6A	MF Input	R/W	UINT	2	0: Extended input 1: All teaching (master only) 2: Light ON/Dark ON switching 3: Test input 4: Off
107	0x6B	Key Lock	R/W	UINT	2	0: Cancel 1: Lock 2: Lock for non-extended input
108	0x6C	Operation mode CH1	R/W	UINT	2	0: Auto
109	0x6D	Operation mode CH2	R/W	UINT	2	1: L-on (Light ON) 2: D-on (Dark ON)
110	0x6E	Threshold level CH1 Lower Limit	R/W	UINT	2	-999 to 9999
112	0x70	Threshold level CH2 Lower Limit	R/W	UINT	2	The writable range varies depending on the operation mode.
114	0x72	Timer setting CH1	R/W	UINT	2	0: Delay OUT
115	0x73	Timer setting CH2	R/W	UINT	2	1: Individual
116	0x74	CH1 Off delay time	R/W	UINT	2	
117	0x75	CH1 On delay time	R/W	UINT	2	0~9999: 0~9999ms
118	0x76	CH2 Off delay time	R/W	UINT	2	-1~-9: 0.1~0.9ms
119	0x77	CH2 On delay time	R/W	UINT	2	
121	0x79	Synchronization	R/W	UINT	2	0: Asynchronous 1: Synchronous
123	0x7B	Sensitivity	R/W	UINT	2	0: 10 % 1: 20 % 2: 50 %

Address No.		Name	Access*	Format (Offset)	Length (Byte)	Value/Range
dec	hex					
125	0x7D	ASC (Automatic Sensitivity Control)	R/W	UINT	2	0: OFF 1: ON
126	0x7E	Eco mode	R/W	UINT	2	0: OFF 1: ON
127	0x7F	Reverse display	R/W	UINT	2	0: Normal display 1: Inverted display
200	0xC8	Store zero-reset	WO	Byte	2	Execute with write operation
201	0xC9	Cancel zero-reset	WO	Byte	2	Execute with write operation
202	0xCA	Teach-in 1-Point	WO	UINT	2	1: Output 1 teaching
203	0xCB	Teach-in 2-Point	WO	UINT	2	2: Output 2 teaching
210	0xD2	Warm start Reset	WO	UINT	2	3: Restart
211	0xD3	Return to top menu	WO	Byte	2	Execute with write operation
212	0xD4	Factory Reset	WO	UINT	2	3: Initialize (Allowed only when unlocked)

\* RO=Read Only, R/W=Read/Write, WO=Write Only

## Errors

High-order byte		Low-order byte		Description
dec	hex	dec	hex	
0	0x0	0	0x0	No error
Applicable address number		1	0x1	The address number is out of range.
		2	0x2	The sub address number is not supported.
0	0x0	3	0x3	An attempt was made to write setting values to sensors that are all locked, or to initialize while locked.
		4	0x4	The teaching target output specification value (1 or 2) is incorrect.
		5	0x5	Teaching mode has no second teaching, or the first has not yet been executed.
		6	0x6	The execution specification value (3) for restart and initialization is incorrect.
Applicable address number		7	0x7	An attempt was made to write a setting value that is out of range.
		8	0x8	The setting value write operation failed. (Attempted to write a read-only setting value)
0	0x0	11	0xB	The amount of light received during teaching was too low.
		12	0xC	The amount of light received during teaching was saturated.
		13	0xD	There was too little difference in the amount of light received during 2-point teaching.
		15	0xF	A hardware error was detected.

## OPTEX FA CO., LTD.

[Headquarters]

91 Chudoji-Awata-cho Shimogyo-ku Kyoto 600-8815  
JAPAN

TEL +81-75-325-1314 FAX +81-75-325-2936

<https://www.optex-fa.com>



Through-beam Edge Sensor

# TD1 Series

OPTEX FA CO. LTD.

## Module Address

Address No.		Name	Access *1	Format (Offset)	Length (Byte)	Value/Range	Address for CDA*2
dec	hex						
1	0x1	Product Type	RO	UINT	2	0x0011	
2	0x2	Firmware Version	RO	UINT	2	0x1011	
3	0x3	Protocol Version	RO	UINT	2	0x0	
4	0x4	Product Revision	RO	UINT	2	Product hardware version	
5	0x5	Vendor Name	RO	STRING	2 to 16	"OPTEX FA"	
6	0x6	Product Name	RO	STRING	2 to 32	Product name	
7	0x7	Product ID	RO	STRING	2 to 32	Product ID	
8	0x8	User Tag Name (Max. 32 bytes)	R/W	STRING	2 to 32	User ID (Max. 32 characters)	
9	0x9	Operation Status	RO	UINT	2	0: Initialize 1: Idle 2: Execute 3: For use by user	
14	0xE	Serial Number	RO	STRING	2 to 32	Set using ASCII code	
98	0x62	Error Status Refer to the separate "Errors" table.	R/W	UINT	2	• Read: Last error code • Write arbitrary value: Delete last error code	
100	0x64	Threshold Near	R/W	UINT	2	-32768~32767	✓
101	0x65	Threshold Far	R/W	UINT	2	0~32767	✓
102	0x66	Output hysteresis	R/W	UINT	2	0: No calculation 1: With calculation	✓
103	0x67	Calculation flags	R/W	UINT	2	0: No calculation 1: With calculation	✓
104	0x68	Calculation coefficient Add (Setting value for each connected sensor)	R/W	UINT	2	-10000~10000	✓
105	0x69	Calculation coefficient Multiply (Setting value for each connected sensor)	R/W	UINT	2		✓
106	0x6A	Calculation coefficient Divide (Setting value for each connected sensor)	R/W	UINT	2	1~32767	✓
107	0x6B	Monitor accumulations	R/W	UINT	2	0: Sensor 2 measured value 1: Calculated value	✓
108	0x6C	Calculation Values Head1	R/W	UINT	2	0: None	
109	0x6D	Calculation Values Head2	R/W	UINT	2	1: Addition	✓
110	0x6E	Calculation Values Unit left Head1	R/W	UINT	2	2: Subtraction	
111	0x6F	Calculation Values Unit left Head2	R/W	UINT	2	3: Absolute value difference	
112	0x70	I/O polarity	R/W	UINT	2	0: PNP (N.O.) 1: NPN (N.O.) 2: PNP (N.C.) 3: NPN (N.C.)	✓
113	0x71	Output Selection CH1	R/W	UINT	2	0: No output 1: Calculated value within threshold range (GO) 2: Calculated value out of range on near side (LO) 3: Calculated value out of range on far side (HI)	
114	0x72	Output Selection CH2	R/W	UINT	2	4: Sensor 1 within threshold range (GO) 5: Sensor 1 out of range on near side (LO) 6: Sensor 1 out of range on far side (HI) 7: Sensor 2 within threshold range (GO) 8: Sensor 2 out of range on near side (LO) 9: Sensor 2 out of range on far side (HI)	✓
115	0x73	Output Selection CH3	R/W	UINT	2		
116	0x74	External input selection	R/W	UINT	2	0: No function 1: Teaching (Far side on rising edge, near side on falling edge) 2: BGS/FGS teaching 3: Zero reset 4: Laser emission OFF	✓
117	0x75	Analog output selection	R/W	UINT	2	0: None 1: Calculated value 2: Sensor 1 3: Sensor 2	✓
118	0x76	Analog scaling	R/W	UINT	2	0: No scaling 1: Scaling	✓
119	0x77	Analog Scaling (max.) 10 V / 20 mA	R/W	UINT	2		✓
120	0x78	Analog Scaling (min.) 0 V / 4 mA	R/W	UINT	2	-32768~32767	✓

Address No.		Name	Access *1	Format (Offset)	Length (Byte)	Value/Range	Address for CDA*2
dec	hex						
121	0x79	Baud rate (Setting value for each connected sensor)	R/W	UINT	2	0: No connection 1: 9.6 kbps 2: 19.2 kbps 3: 38.4 kbps 4: 57.6 kbps 5: 115.2 kbps 6: 230.4 kbps 7: 312.5 kbps 8: 468.75 kbps 9: 500 kbps 10: 625 kbps 11: 833.3 kbps 12: 937.5 kbps 13: 1250 kbps	✓
129	0x81	Amplifier product code	RO	UINT	2	0x2503	✓
134	0x86	Average Number	R/W	UINT	2	1~128	
135	0x87	Measurement Type	R/W	UINT	2	0: Edge positive 1: Edge negative 2: Width	
136	0x88	Sampling rate	R/W	UINT	2	0: 500µs (Fixed value)	
143	0x8F	Measuring direction	R/W	UINT	2	0: Top to Bottom 1: Bottom to Top	
144	0x90	Zeroing value	RO	UINT	2	-9999~5000	
152	0x98	Sensitivity	R/W	UINT	2	0: Minimum value 1: Second value 2: Third value 3: Fourth value 4: Maximum value 5: Adjustment value	
200	0xC8	Save zero-reset	WO	Byte	2	Execute with write operation	
201	0xC9	Cancel zero-reset	WO	Byte	2	Execute with write operation	
212	0xD4	Factory Reset	WO	UINT	2	3: Initialize	

\*1. RO=Read Only, R/W=Read/Write, WO=Write Only

\*2. Displacement Sensor Amplifier Unit

## Errors

High-order byte		Low-order byte		Description
dec	hex	dec	hex	
0	0x0	0	0x0	No error
Applicable address number		1	0x1	The address number is out of range.
		2	0x2	The sub address number is not supported.
		3	0x3	The ETX code in the command string is invalid.
		4	0x4	A checksum error was detected.
		5	0x5	The command code is invalid.
		6	0x6	A non-regulated parameter was specified.
		7	0x7	An out of range numeric value was specified.
		8	0x8	Reserved
		9	0x9	Reserved

**OPTEX FA CO., LTD.**

[Headquarters]

91 Chudoji-Awata-cho Shimogyo-ku Kyoto 600-8815  
JAPAN

TEL +81-75-325-1314 FAX +81-75-325-2936

<https://www.optex-fa.com>

IO-Link GATEWAY

# UC2-IOL

Download the index list, the IO-Link setting file (IODD file) and the connected module operation manual from the Optex FA website.  
<https://www.optex-fa.com>



**OPTEX FA CO.,LTD.**

- Thank you for purchasing this IO-Link Gateway UC2-IOL.
- Before using this product, please read this manual carefully to ensure proper use.
- Read this manual thoroughly, and then keep this manual at hand so that it can be used whenever necessary.
- The warranty period of this product is one year after delivery. However, any fault attributable to natural disasters or any other similar disasters or modification or repair will be excluded from the scope of the warranty.

## Safety Precautions

Safety precautions for ensuring safe operation of this product are displayed as follows with the following symbols.

Precautions listed here describe important information about safety. Make sure to follow them accordingly.

### Safety Symbols

	<b>WARNING</b> Indicates that any improper operation or handling may result in moderate or minor injury, and in rare cases, serious injury or death. Also indicates a risk of serious property damage.
	<b>CAUTION</b> Indicates that any improper operation or handling may result in minor injury or property damage.

<b>WARNING</b>	
	Do not disassemble, repair, modify, deform under pressure, or attempt to incinerate this product. Doing so may cause injury or fire.
	This product is not explosion-proof and should not be used around flammable or explosive gases or liquids. Doing so may cause ignition resulting in an explosion or fire.
	Do not use air dusters or any spray that uses flammable gas around the product or on the inside of the product. Doing so may cause ignition resulting in an explosion or fire.
	Do not install this product in any of the following locations. Doing so may cause a fire, damage, or a malfunction. <ol style="list-style-type: none"> <li>1. Locations where dust, salt, iron powders, or vapor (steam) is present.</li> <li>2. Locations subjected to corrosive gases or flammable gases.</li> <li>3. Locations where oil or chemical splashes may occur.</li> <li>4. Locations where heavy vibrations or impacts may occur.</li> <li>5. Locations where the ambient temperature exceeds the rated range.</li> <li>6. Locations subject to rapid temperature changes (or where condensation occurs).</li> <li>7. Locations with strong electric or magnetic fields.</li> <li>8. Outdoor locations or locations subject to direct light.</li> </ol>
	This is a class A product. In a domestic environment this product may cause radio interference, in which case the user may be required to take adequate measures.
	This product is not intended for use with nuclear power, railways, aviation, vehicles, medical equipment, food-handling equipment, or any application where particular safety measures are required. Absolutely do not use this product for any of these fields.
	This product cannot be used in applications that directly or indirectly detect human bodies for the purpose of ensuring safety. Do not use this product as a detection device for protecting the human body.
	What to do in the event of a malfunction such as smoke being emitted from the product if you detect any malfunction including emission of smoke, abnormal smells or sounds, or the body becoming very hot, immediately stop operating the product and turn off the sensor power. Failure to do so may cause a fire. Repairing the product is dangerous and should in no way be performed by the customer. Contact an OPTEX FA sales representative for repairs.

<b>CAUTION</b>	
	<ul style="list-style-type: none"> <li>• Make sure to turn the power off before wiring the cable or connecting/disconnecting the connector. Connecting or disconnecting while energized may damage the product or cause electric shock.</li> <li>• Do not wire with high voltage cables or power lines. Doing so may cause malfunction or damage by induction.</li> <li>• Do not bend the cable when below the freezing point. This may cause the cable to break.</li> <li>• Do not drop the product or subject the product to strong impacts. Doing so may damage the product.</li> <li>• Follow the instructions in this manual or the specified instruction manual when wiring the product or the dedicated controller for the correct wiring method. Incorrect wiring can damage the product or the controller, or cause a malfunction.</li> <li>• When disconnecting the connector, be careful not to touch the terminals inside the connector, and do not allow foreign objects to enter the connector.</li> <li>• Install this product as far away as possible from high-voltage equipment, power equipment, equipment that generates large switching surges, inverter motors, welders, or any equipment that can be a source of noise.</li> <li>• When connecting or disconnecting the cable, make sure to hold it by the connector portion, and do not apply excessive force to the cable.</li> </ul>

### NOTICE

- After carefully considering the intended use, required specifications, and usage conditions, install and use the product within the specified ranges.
- All specifications may be changed without notice.
- When using this product, it is the responsibility of the customer to ensure necessary safety designs in hardware, software, and systems in order to prevent any threat to life, physical health, and property due to product malfunction or failure.
- Do not use this product for the development of weapons of mass destruction, for military use, or for any other military application. Moreover, if this product is to be exported, comply with all applicable export laws and regulations, including the "Foreign Exchange and Foreign Trade Act" and the "Export Administration Regulations," and carry out the necessary procedures pursuant to the provisions therein.
- For more details on conformity to the Restriction of Hazardous Substances Directive for this product, please contact an OPTEX FA sales representative. Before using this product, fully examine the applicable environmental laws and regulations, and operate the product in conformity to such laws and regulations. OPTEX FA does not assume any responsibility for damages or losses occurring as a result of noncompliance with applicable laws and regulations.

## 1. Included Accessories

- Instruction manual (this manual)
- Mounting bracket

## 2. Dimensions

UC2-IOL (with mounting bracket equipped)

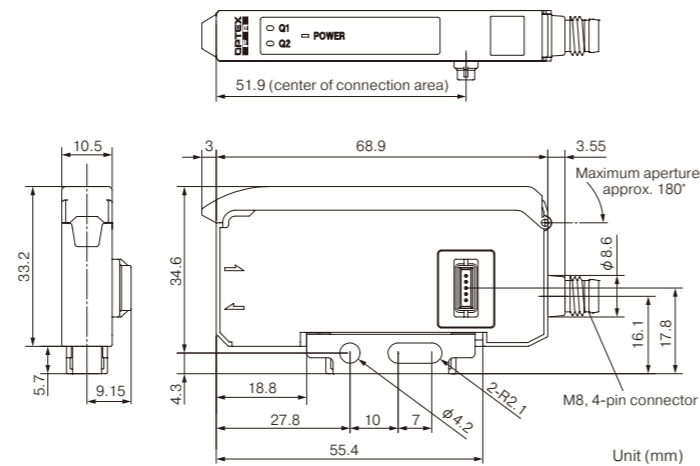

## 3. I/O Circuit Diagrams

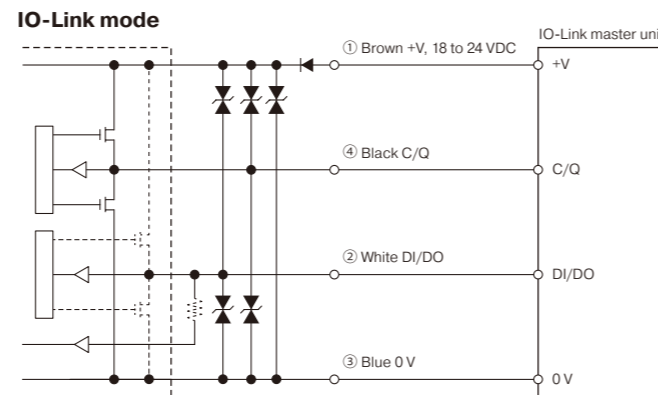

SIO mode (standard I/O mode) with push-pull

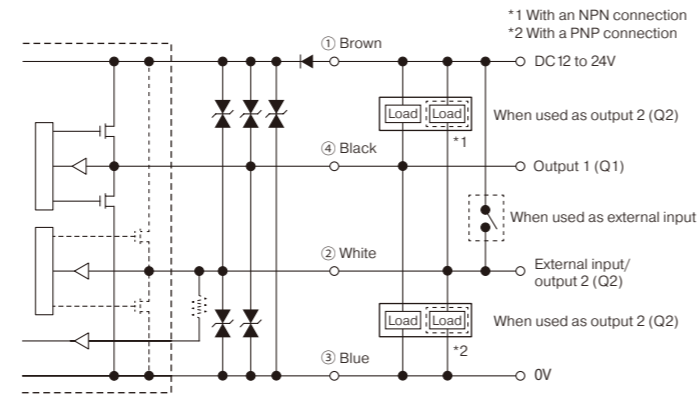

### M8 connector pin numbers

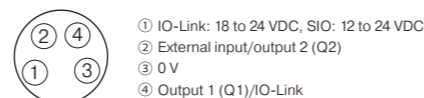

## 4. Part Names

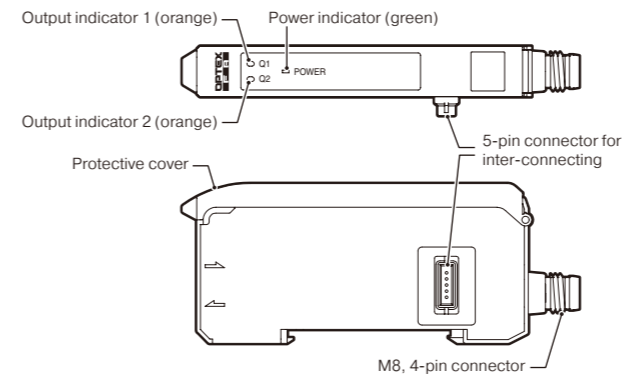

## 5. Lists of Cables and Connectable Models

### Connector cables

(For UC2-IOL and D3RF/D3WF series connector types)

Series name	Model	Type
M84CN series (M8, 4-pin connector cable)	M84CN-2S	2 m long
	-5S	5 m long
	-10S	10 m long
*This is required when four or more D3RF/D3WF connector type master units are inter-connected.		

### Fiber amplifiers

Series name	Model	Type	
D3RF series (red light source)	D3RF-TMN	Inter-connection master unit, cable type	
	-TMP	cable type	
	-TMCN4	connector type	
	-TMCN4	connector type	
	-TDMN	cable type, two outputs	
	-TDMP	cable type, two outputs	
	D3RF-TSN	D3RF-TSN	Inter-connection slave unit, cable type
		-TSP	cable type
-TSCN4		connector type	
-TSCP4		connector type	
-TDSN		cable type, two outputs	
-TDSP		cable type, two outputs	
D3WF series (white light source)	D3WF-TMCN4	Inter-connection master unit, connector type	
	D3WF-TSCN4	Inter-connection slave unit, connector type	

### Displacement sensor amplifier units

Series name	Model	Type
CDA series	CDA-M	Inter-connection master unit
	-DM2	Inter-connection slave unit
CDA-S		Inter-connection slave unit

### Displacement sensors/edge sensors

(Use the CDA series to connect these sensors.)

Series name/product name	Model	Type
CD22 series (laser displacement sensor)	CD22-15-485M12	RS-485 communication type
	-35-485M12	*DSL-1204-G02M connector cable is required to connect to the CDA.
	-100-485M122	
Amplifier connection cable	DSL-1204-G02M	Cable for connecting to the CDA, 2 m long
TD1 series (through-beam edge sensor)	TD1-010M8	
CD22/TD1 extension cable	DSL-0804-G02M	Sensor head extension cable, 2 m long
	-G05M	Sensor head extension cable, 5 m long

\*These are lists of connectable models as of January 2020. There are plans to add products sequentially, so contact OPTEX FA for details on models that are not listed here.

## 6. Installation

### Installation on DIN rail or the included mounting bracket

Hook the indicator-side tab on the DIN rail or the included mounting bracket (1), and then press down until the hook locks (2).

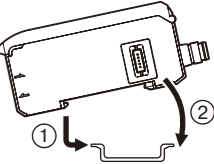

### Removal

While pressing the main unit in the direction of (1), lift the indicator side (2) to remove the main unit.

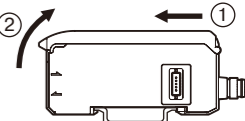

### Inter-connecting with fiber amplifiers and displacement sensor amplifier units

To inter-connect all the units, slide the fiber amplifiers and displacement sensor amplifier units along the DIN rail that the UC2 is attached to.

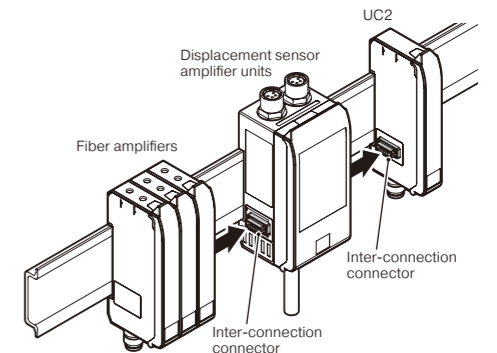

### CAUTION

- Be sure to turn off the power before performing this work.
- When inter-connecting, check the ambient temperature and use the units within the operating range for the ambient temperature.
- To prevent short-circuits, be sure to attach the included protective caps for connector types of fiber amplifiers to connecting terminals that are not in use. For cable types, prevent lead wires that are not in use from connecting to the other terminals by, for example, cutting these lead wires and wrapping them individually with insulating tape.
- Do not remove these units/amplifiers from the DIN rail while multiple units are inter-connected.

### Installing end plates (sold separately)

To prevent the inter-connected units from coming loose, attach end plates (sold separately; model: BEF-EB01-W190) to the DIN rail so that they surround the inter-connected units and fix the end plates in place with screws.

Orient the end plates so that the product side is against the unit and the fiber amplifiers, making sure to attach the left and right sides in opposite orientations. Attach the end plates by hooking the notched side on the DIN rail first, as shown in the following diagram. Use a tightening torque of 0.9 N·m or less.

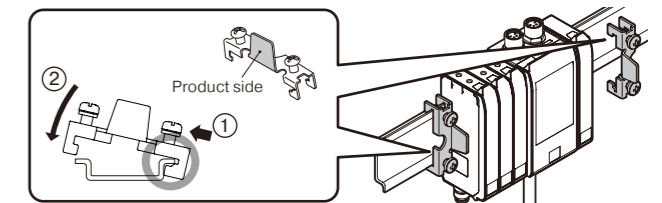

### CAUTION

When inter-connecting the unit to D3RF/D3WF series fiber amplifiers and to CDA series displacement sensor amplifier units, be sure to connect the inter-connection master unit on the left end (ID = 1). If an inter-connection slave unit is connected on the left end, the inter-connection connector will be exposed, causing interference with the end plate. Also, fouling on or damage to the inter-connection connector may damage the fiber amplifiers.

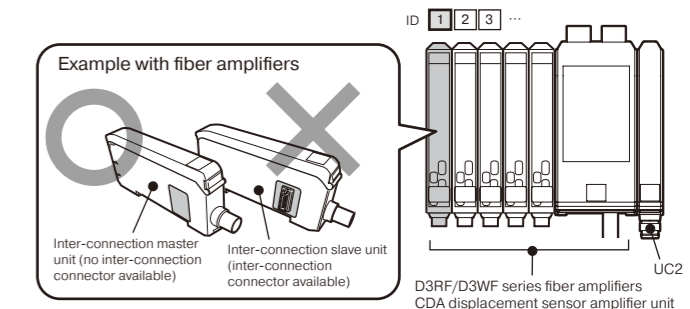

## 7. Connecting

### Connecting the connector cable (sold separately)

Use M84CN-□S M8 connector cable to connect to the IO-Link master unit. Check the orientation of the connector pins on the unit side and on the connector cable side and attach the cable correctly.

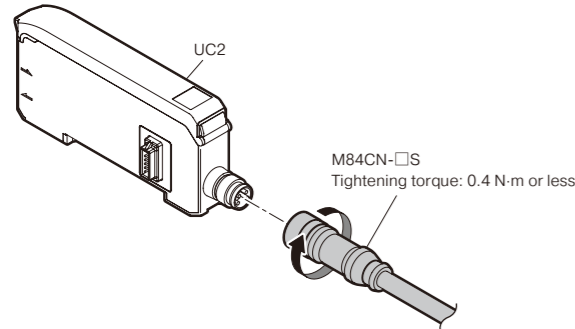

The UC2 operates with a supply voltage of 18 to 24 VDC (12 to 24 VDC in SIO mode). Be sure to check the wiring to the IO-Link master unit and to the power supply device because incorrect wiring may cause a fire or damage the product.

### Connecting UC2 to CDA units (connecting to CD22 and TD1 units)

To connect the UC2 to CD22 series laser displacement sensors and to TD1 series through-beam edge sensors, connect through CDA series displacement sensor amplifier units.

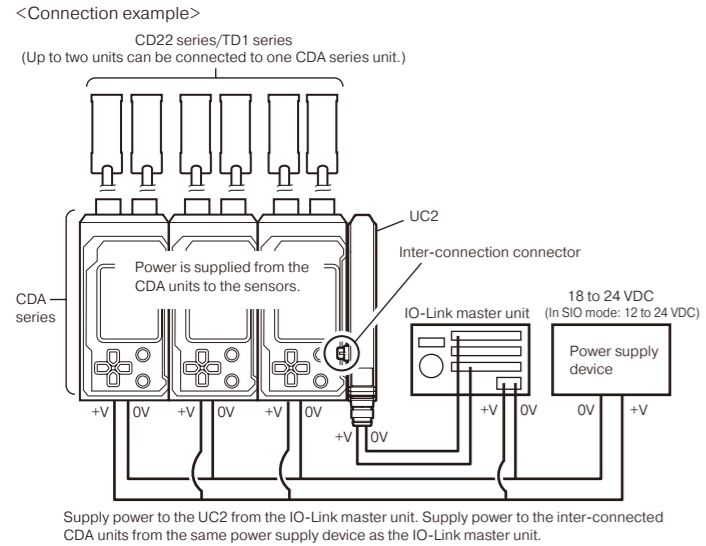

#### CAUTION

- The CDA series power supply must be connected to a power supply that is separate from that for the UC2 and is the same as that for the IO-Link master unit.
- Power is supplied to the CD22 series and to the TD1 series from the CDA series. The UC2 can be inter-connected to CDA series master units and slave units.
- When inter-connecting the UC2 to the CDA series, be sure to inter-connect the inter-connection master unit on the left end. If an inter-connection slave unit is connected on the left end, the inter-connection connector will be exposed, damaging the product.
- Up to eight CDA series units can be inter-connected. Depending on the settings, all the output information and distance information of up to 7 sensors or all the output information of up to 16 sensors and the distance information of up to 5 sensors can be acquired.
- Ensure that the length of the power cable to the unit and to the CDA series is 20 m or less.
- The operating temperature of the CDA series slave unit (CDA-S) and the load current of the control output are restricted by the connected master unit (CDA-M, CDA-DM2) as below.

<CDA-M+CDA-S>		
Operating temperature	-25 to +50°C	
Load current of control output	Up to 100mA per output channel	Up to 100mA per output channel (Up to 2A including self-consumption)
Number of connected units	1 unit (Only CDA-M)	2 to 8 units

<CDA-DM2+CDA-S>		
Operating temperature	-25 to +50°C	-20 to +45°C
Load current of control output	Up to 100mA per output channel	Up to 20mA per output channel
Number of connected units	1 unit (Only CDA-DM2)	2 to 8 units

### Connecting UC2 to D3RF/D3WF series

Use the inter-connection connectors to connect the UC2 to D3RF/D3WF series fiber amplifiers.

#### Connecting power supply wires

When three or less fiber amplifiers are inter-connected to the UC2, the fiber amplifiers operate with the power supplied from the inter-connection connector of the UC2. When four or more fiber amplifiers are inter-connected to the UC2, connect the inter-connection master unit on the left end to the same power supply as the IO-Link master unit.

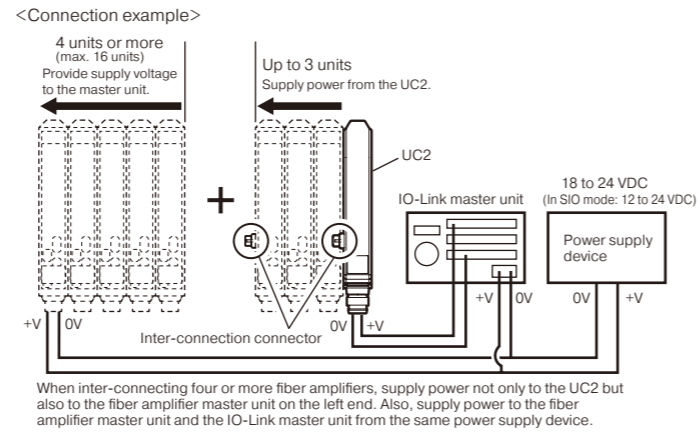

#### Fiber amplifier inter-connection order

When inter-connecting the unit to D3RF series and D3WF series fiber amplifiers, do so with all the D3WF units closest to the unit and all the D3RF units farthest away.

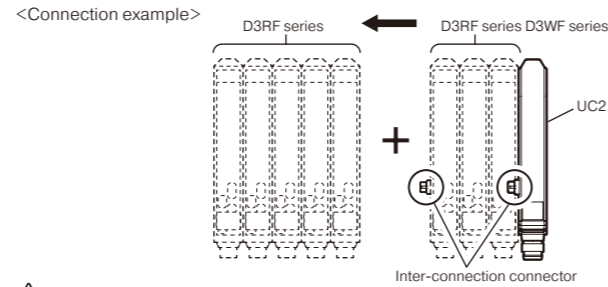

#### CAUTION

- When inter-connecting the unit to fiber amplifiers, be sure to connect an inter-connection master unit on the left end. If an inter-connection slave unit is connected on the left end, the inter-connection connector will be exposed, damaging the product.
- A total of up to 16 D3RF series and D3WF series fiber amplifiers can be inter-connected. Depending on the settings, all the output information and receiving light level information of up to 7 sensors or all the output information of up to 16 sensors and the receiving light level information of up to 5 sensors can be acquired.
- Ensure that the length of the power cable to the unit and to the fiber amplifiers is 20 m or less.
- When using a cable type fiber amplifier, perform insulation processing to prevent the power supply wires (brown/blue) from short-circuiting. Short-circuits may lead to device damage. Furthermore, in the case of connector type units, connect the included black cap to the M8 connector when the connector cable is not connected to prevent the pins from short-circuiting.
- The operating temperature and the load current of control output are restricted by the number of connected units as below:

No. of connected unit	1 to 3 unit(s)	4 to 8 units	9 to 16 units
Operating temperature	-25 to +55°C	-25 to +50°C	-25 to +45°C
Load current of control output	100 mA	50 mA	20 mA

### Connecting UC2 to a combination of CDA series and D3RF/D3WF series units

When inter-connecting the unit to CDA displacement sensor amplifier units and to D3RF/D3WF series fiber amplifiers, do so with all the CDA units closest to the unit, all the D3WF units next closest to the unit, and all the D3RF units farthest away.

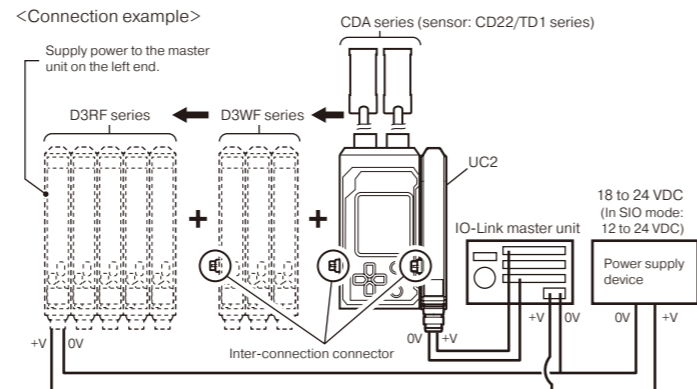

- Supply power to the UC2 from the IO-Link master unit. Furthermore, supply power not only to the UC2 but also to the fiber amplifier master unit on the left end.
- Connect the fiber amplifier master unit and the IO-Link master unit to the same power supply device.
- For the CDA, use an inter-connection slave unit.

#### CAUTION

- Supply power to the CDA series and D3RF/D3WF series units from the same power supply as that for the IO-Link master unit.
- When inter-connecting the UC2 to the CDA series, be sure to inter-connect the inter-connection master unit on the left end. If an inter-connection slave unit is connected on the left end, the inter-connection connector will be exposed, damaging the product.
- A total of up to 16 D3RF/D3WF series and CDA series units can be inter-connected. (One CDA displacement sensor amplifier unit counts as two sensors.) Depending on the settings, all the output information and distance/receiving light level information of up to 7 sensors or all the output information of up to 16 sensors and the distance/receiving light level information of up to 5 sensors can be acquired.
- Ensure that the length of the power cable to the unit and to the CDA series is 20 m or less.
- When using a cable type D3RF/D3WF series unit, perform insulation processing to prevent the power supply wires (brown/blue) from short-circuiting. Short-circuits may lead to device damage. Furthermore, in the case of connector type units, connect the included black cap to the M8 connector when the connector cable is not connected to prevent the pins from short-circuiting.

## 8. System Configuration Example

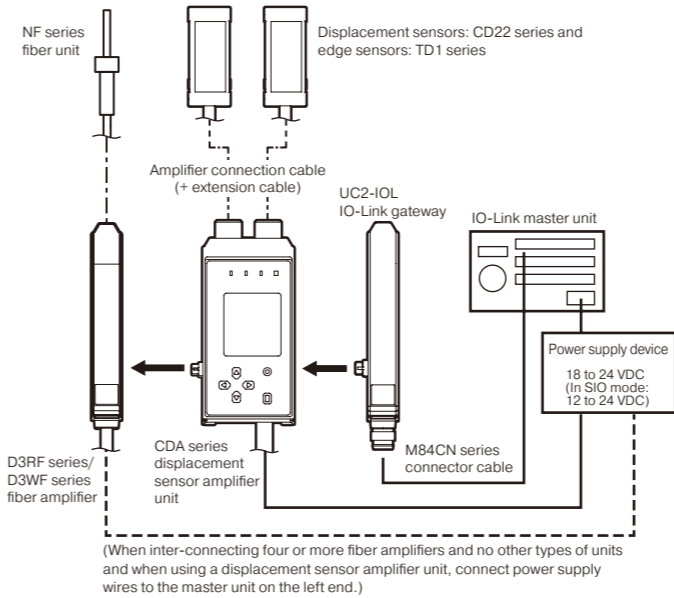

- The UC2 can be inter-connected to up to a total of 16 sensors. (One CDA displacement sensor amplifier unit counts as two sensors.) Depending on the settings, all the output information and distance/receiving light level information of up to 7 sensors or all the output information of up to 16 sensors and the distance/receiving light level information of up to 5 sensors can be acquired.
- The power supply connections of the devices vary depending on the devices that are connected and on the number of devices that are connected. Check the information under "7. Connecting" and connect the power supplies correctly.

## 9. Specifications

Model		UC2-IOL	
IO-Link communication specifications	Minimum cycle time	2.0 ms	
	Baud rate	COM3 (230.4 kbps)	
	ISDU support	Available	
	IO-Link revision	1.1	
	Number of process input data bytes	16	
	Number of process output data bytes	0	
	IO-Link frame type	F-Sequence Type 2.V	
	IODD revision	1.1.0	
	Connected devices	Connectable models	D3RF series/D3WF series inter-connection master unit and slave unit CDA series master unit and slave unit
		Number of connectable units	Up to 16 (One CDA unit requires two spaces.)
Connection type		5-pin connector for inter-connection (functions as an inter-connection end unit)	
Indicators	Power indicator (green), SIO: lit at all times, IO-Link: flashing		
	Output indicator × 2 (orange)		
Ratings	Supply voltage	SIO: 12 to 24 Vdc including 10% of ripple (P-P) IO-Link: 18 to 24Vdc including 10% of ripple (P-P) (Class 2 or SELV+LIM)*1	
	Current consumption	40 mA max.*2	
Control output	Push-Pull × 2 outputs, max. 100 mA/24 VDC (total for 2 outputs) Residual voltage: 1.8 V or less		
External input	Teaching input, smart task input		
Connection type	Connector type: M8, 4-pin		
Warm-up time	With 1 D3RF/D3WF unit inter-connected: 300 ms, with 16 D3RF/D3WF units inter-connected: 350 ms CDA + CD22: 2.5 s CDA + TD1: 350 ms		
Protection circuit	Reverse connection protection, overcurrent protection		
Environmental resistance	Installation location	Indoor use	
	Operating temperature/humidity	-25 to +55°C (no freezing)/35 to 85%RH (no condensation)	
	Storage temperature/humidity	-40 to +70°C (no freezing)/35 to 95%RH (no condensation)	
	Vibration resistance	10 to 55 Hz; double amplitude 1.5 mm; 2 hours in each of the X, Y, and Z directions	
	Shock resistance	Approx. 50 G (500 m/s <sup>2</sup> ); 3 times in each of the X, Y, and Z directions	
Applicable regulations	Degree of protection	IP50 (According to IEC 60529)	
	Pollution degree	2 or less	
	Operating altitude	2000 m or less	
Applicable standards	EMC	EMC directive (2014/30/EU)	
	Environment	RoHS directive (2011/65/EU), China RoHS (MIIT Order No. 32)	
Applicable standard	EN 60947-5-2		
Company standards	Noise resistance: Feilen Level 3 cleared		
Weight	Approx. 16 g		
Material	Housing and protective cover: PC		
Included accessories	Instruction manual, mounting bracket		

\*1. Use a Class 2 power supply or a power supply that conforms to the SELV circuit (Safety Extra-Low Voltage) and the LIM circuit (Limited Energy Circuit).  
\*2. Not including control output load current.

This device complies with part 15 of the FCC Rules. Operation is subject to the following two conditions: (1) This device may not cause harmful interference, and (2) this device must accept any interference received, including interference that may cause undesired operation.

\* This equipment has been tested and found to comply with the limits for a Class A digital device, pursuant to part 15 of the FCC Rules. These limits are designed to provide reasonable protection against harmful interference when the equipment is operated in a commercial environment. This equipment generates, uses, and can radiate radio frequency energy and, if not installed and used in accordance with the instruction manual, may cause harmful interference to radio communications. Operation of this equipment in a residential area is likely to cause harmful interference in which case the user will be required to correct the interference at his own expense.

- Support for the China RoHS directive

For details on the support for the China RoHS directive (the Administrative Measure on the Control of Pollution Caused by Electronic Information Products), see the following website: [https://www.optex-fa.com/rohs\\_cn/](https://www.optex-fa.com/rohs_cn/)

## OPTEX FA CO., LTD.

[Headquarters]

91 Chudoji-Awata-cho Shimogyo-ku Kyoto 600-8815 JAPAN

TEL +81-75-325-1314 FAX +81-75-325-2936

<https://www.optex-fa.com>