



More Precision

wireSENSOR // Draw-wire displacement sensors





- Robust aluminum profile housing
- Customized versions for OEM
- Incremental / absolute encoder

Model P200

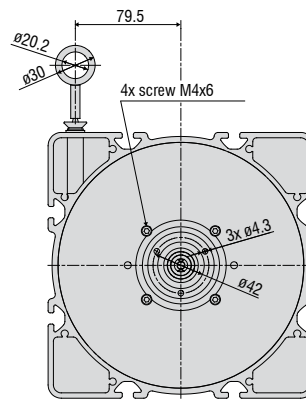
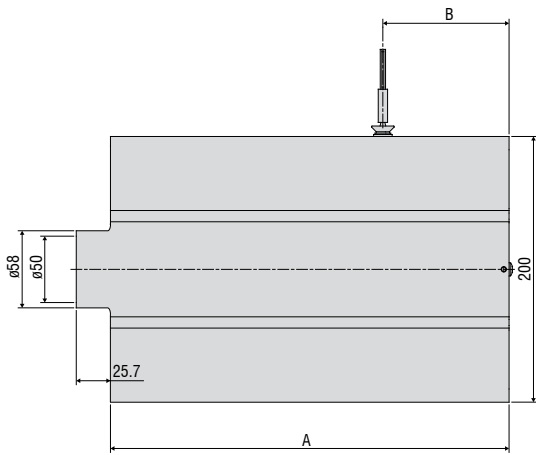

MR (mm)	A (mm)	B (mm)
30000	268	75
40000	300	95
50000	333.5	95

Output P200-HTL/TTL

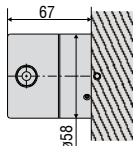

Output P200-SSI

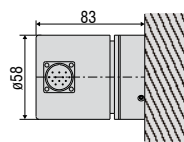

Output P200-CO/PB

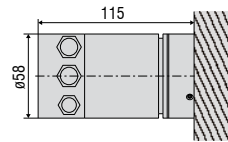

Model	WDS-30000-P200	WDS-40000-P200	WDS-50000-P200	
Measuring range	30000mm	40000mm	50000mm	
Output	HTL, TTL, SSI, PB, CO			
Travel per encoder revolution	500mm			
Linearity	±0.01% FSO	±3mm	±4mm	±5mm
Resolution	HTL, TTL	0.167mm (6 pulses/mm)		
	SSI, PB, CO	0.061mm		
Temperature range	-20 °C ... +80 °C			
Sensor element	incremental/absolute encoder			
Material	housing	aluminum		
	draw-wire	coated polyamide stainless steel (ø 0.8mm)		
Wire mounting	eyelet			
Sensor mounting	slot nuts			
Wire acceleration	2g			
Wire retraction force (min)	12N	11N	11N	
Wire extension force (max)	22N	22N	24N	
Protection class	IP65			
Electrical connection	HTL, TTL	integrated cable, radial, 1m		
	SSI	flange connector, radial, 12-pin		
	PB, CO	bus cover		
Weight	approx. 10kg	approx. 11kg	approx. 12kg	

FSO = des Messbereichs
Specifications for digital outputs on page 52.

Article description

WDS - 30000 - P200 - CR - TTL

Output options:
HTL
TTL
CO: CANopen
PB: Profibus DP
SSI

Connection:
SR (Output SSI): radial plug
CR (Output HTL, TTL): integrated cable, radial, 1m
BH (Output CO, PB): bus cover

Model P200

Measuring range in mm

Accessories:

WE-xxx-M4	Wire extension with M4-wire connection, x=length
WE-xxx-Clip	Wire extension with eyelet, x=length
TR1-WDS	Pulley wheel, adjustable
TR3-WDS	Pulley wheel, fixed
GK1-WDS	Attachment head for M4
MH1-WDS	Magnetic holder for wire mounting
MH2-WDS	Magnetic holder for sensor mounting
MT-60-WDS	Mounting clamp for WDS-P60
FC8	Female connector for WDS, 8-pin
FC8/90	Female connector 90° for WDS
PC 3/8-WDS	Sensor cable, length 3m
PS 2020	(Power Supply 24 V / 2,5 A, Input 100 - 240 VAC, output 24 VDC / 2.5 A, for snap in mounting on DIN 50022 rail)
WDS-MP60	Mounting plate for P60 sensors

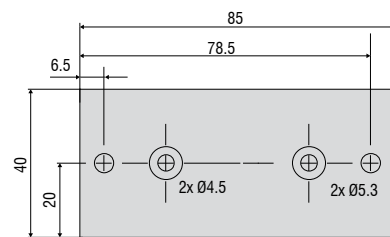
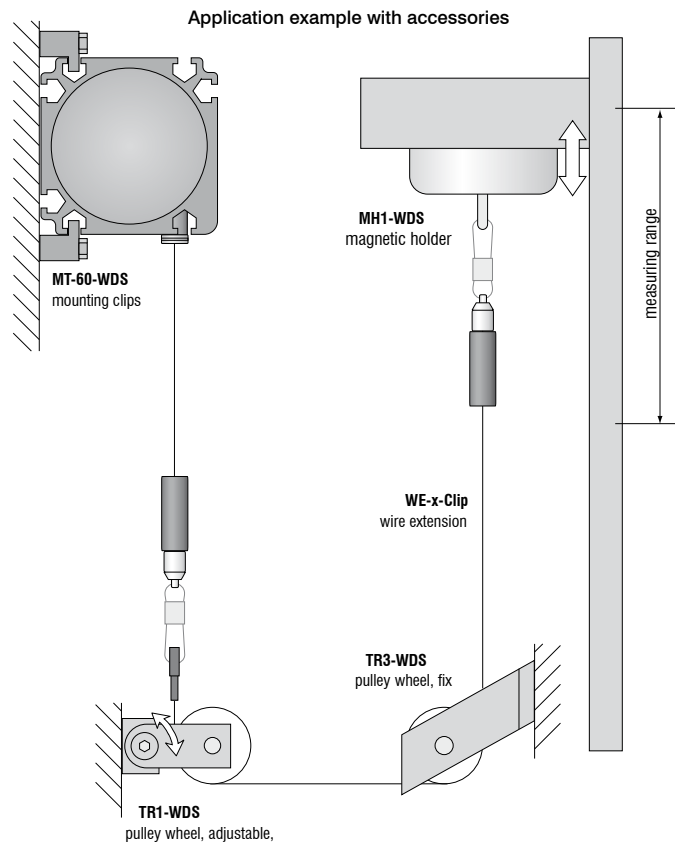

Mounting plate WDS-MP60

Installation information:

Wire attachment: The free return of the measurement wire is not permissible and it is essential that this is avoided during installation.

Wire exit angle:

When mounting a draw-wire displacement sensor, a straight wire exit ($\pm 3^\circ$ tolerance) must be taken into account. If this tolerance is exceeded, increased material wear on the wire and at the wire aperture must be expected.

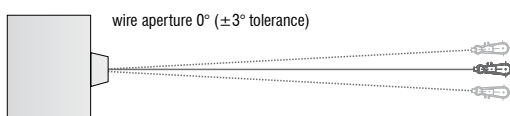

Contact description

1 UB	Encoder power supply connection
2 GND	Encoder ground connection. The voltage drawn to GND is UB.
3 Pulses +	Positive SSI pulse input. Pulse + forms a current loop with pulse -. A current of approx. 7 mA in direction of pulse + input generates a logical 1 in positive logic.
4 Data +	Positive, serial data output of the differential line driver. A High level at the output corresponds to logical 1 in positive logic.
5 ZERO	Zero setting input for setting a zero point at any desired point within the entire resolution. The zeroing process is triggered by a High pulse (pulse duration ≥ 100 ms) and must take place after the rotating direction selection (UP/DOWN). For maximum interference immunity, the input must be connected to GND after zeroing.
6 Data -	Negative, serial data output of the differential line driver. A High level at the output corresponds to logical 0 in positive logic.
7 Pulses -	Negative SSI pulse input. Pulse - forms a current loop with pulse +. A current of approx. 7 mA in direction of pulse - input generates a logical 0 in positive logic.
8 / 10 <u>DATAVALID</u> <u>DATAVALID MT</u>	Diagnosis outputs DV and DV MT Jumps in data word, e.g. due to defective LED or photoreceiver, are displayed via the DV output. In addition, the power supply of the multiturn sensor unit is monitored and the DV MT output is set when a specified voltage level is dropped below. Both outputs are Low-active, i.e. are switched through to GND in the case of an error.
9 UP/DOWN	UP/DOWN counting direction input. When not connected, this input is on High. UP/ DOWN-High means increasing output data with a clockwise shaft rotating direction when looking at the flange. UP/ DOWN-Low means increasing values with a counter-clockwise shaft rotating direction when looking at the flange.
11 / 12	Not in use

Pin assignment

Pin	Cable color	Assignment
1	brown	UB
2	black	GND
3	blue	Pulses +
4	beige	Data +
5	green	ZERO
6	yellow	Data -
7	violet	Pulses -
8	brown/yellow	<u>DATAVALID</u>
9	pink	UP/ DOWN
10	black/yellow	<u>DATAVALID</u> <u>MT</u>
11	-	-
12	-	-

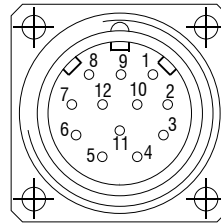

Please use leads twisted in pairs for extension cables.

Inputs

Control signals UP/DOWN and Zero

Level High	> 0.7 UB
Level Low	< 0.3 UB
Connection:	UP/DOWN input with 10kohms to UB, zeroing input with 10kohms to GND.
SSI pulse	

Optocoupler inputs for electrical isolation

Outputs

SSI data	RS485 driver	
Diagnostic outputs		
Push-pull outputs are short-circuit-proof		
Level High	> UB -3.5V	(with I = -20mA)
Level Low	$\leq 0.5V$	(with I = 20mA)

CANopen features	
Bus protocol	CANopen
Device profile	CANopen - CiA DSP 406, V 3.0
CANopen Features	Device Class 2, CAN 2.0B
Operating modes (with SDO progr.)	Polling Mode (asynch, via SDO) Cyclic Mode (asynch-cyclic) The encoder cyclically sends the current process actual value without a request by a master. The cycle time can be parameterized for values between 1 and 65535 ms. Synch Mode (synch-cyclic) The encoder sends the current actual process value after receiving a synch telegram sent by a master. The synch counter in the encoder can be parameterized so that the position value is not sent until after a defined number of synch telegrams. Acyclic Mode (synch-acyclic)
Preset value	With the "Preset" parameter the encoder can be set to a desired actual process value that corresponds to the defined axis position of the system. The offset value between the encoder zero point and the mechanical zero point of the system is saved in the encoder.
Rotating direction	With the operating parameter the rotating direction in which the output code is to increase or decrease can be parameterized. Scaling The steps per revolution and the total revolution can be parameterized.
Scaling	The steps per revolution and the total revolution can be parameterized.
Diagnose	The encoder supports the following error messages: - Position and parameter error - Lithium cell voltage at lower limit (Multiturn)
Default setting	50kbit/s, node number 1

Baud rate	Setting Dip Switch		
	1	2	3
10kBit/s	OFF	OFF	OFF
20kBit/s	OFF	OFF	ON
50kBit/s	OFF	ON	OFF
125kBit/s	OFF	ON	ON
250kBit/s	ON	OFF	OFF
500kBit/s	ON	OFF	ON
800kBit/s	ON	ON	OFF
1MBit/s	ON	ON	ON

Contact description CANopen	
CAN_L	CAN Bus Signal (dominant Low)
CAN_H	CAN Bus Signal (dominant High)
UB	Supply voltage 10...30VDC
GND	Ground contact for UB
(Terminals with the same designation are internally interconnected)	

Settings of user address for CANopen
 Address can be set with rotary switch. Example: User address 23

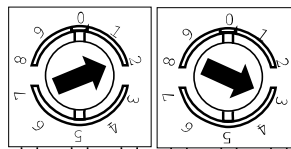
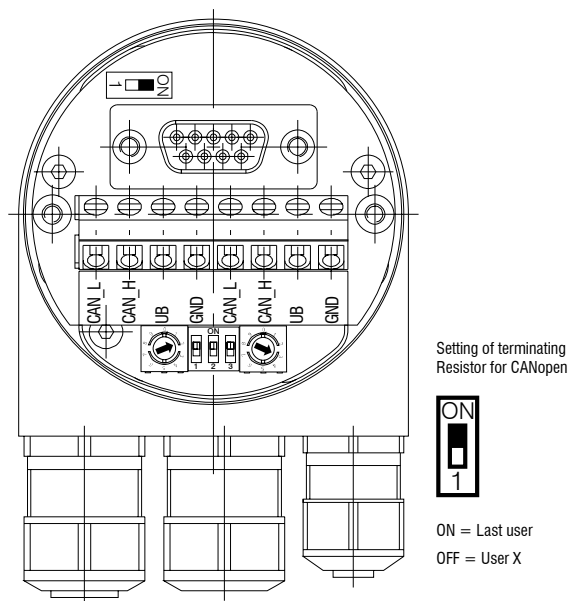

Profibus-DP features

Bus protocol	Profibus-DP
Profibus features	Device Class 1 and 2
Data exch. functions	Input: Position value Additional parameterized speed signal (readout of the current rotary speed) Output: Preset value
Preset value	With the "Preset" parameter the encoder can be set to a desired actual value that corresponds to the defined axis position of the system.
Parameter functions	Rotating direction: With the operating parameter the rotating direction for which the output code is to increase or decrease can be parameterized.
Diagnose	The encoder supports the following error messages: - Position error - Lithium cell voltage at lower limit (Multiturn)
Default setting	User address 00

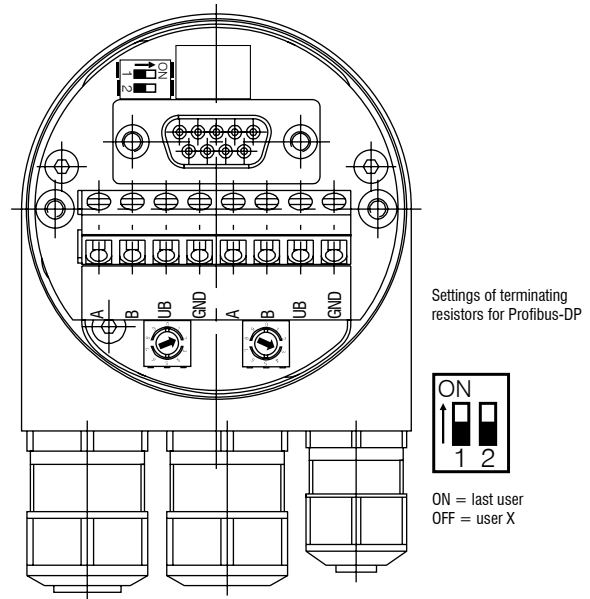
**Settings of user address for Profibus-DP**

Settings of user address for Profibus-DP

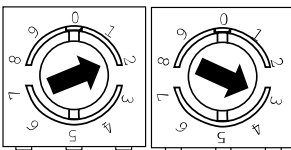
**Contact description Profibus-DP**

A Negative serial data line

B Positive serial data line

UB Supply voltage 10...30VDC

GND Ground contact for UB

(Terminals with the same designation are internally interconnected)

Signal output

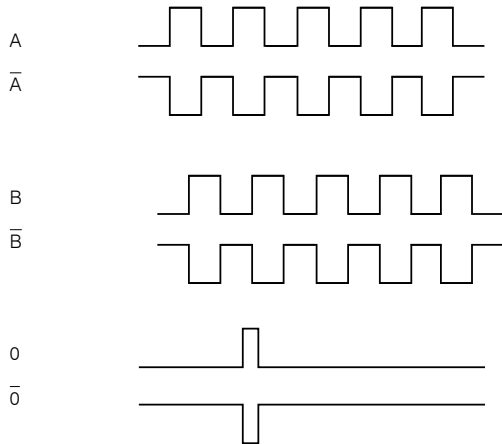

Output TTL	Linedriver (5 VDC)	
Level High	$\geq 2.5V$	(with I = -20mA)
Pegel Low	$\leq 0.5V$	(with I = 20mA)
Load High	$\leq 20mA$	
Output	A, \bar{A} , B, \bar{B} , 0	

Output TTL01/TTL02	NPN (5 VDC $\pm 5\%$)	
Level High	$> 4.5V$	
Level Low	$< 1.0V$	
Load High	$\leq 3mA$	
Output (TTL01)	A, B, 0	
Output (TTL02)	A, \bar{A} , B, \bar{B} , 0	

Output HTL	Push-pull (10 ... 30 VDC)	
Level High	$\geq UB - 3V$	(with I = -20mA)
Level Low	$\leq 1.5V$	(with I = 20mA)
Load High	$\leq 40mA$	
Output	A, \bar{A} , B, \bar{B} , 0	

Output E	Push-pull ((5 VDC)	
Level High	$\geq UB - 2.5V$	
Level Low	$\leq 0.5V$	
Load High	$\leq 50mA$	
Output	A, B, 0	

Output E830	Push-pull ((8 ... 30 VDC)	
Level High	$\geq UB - 3V$	
Level Low	$\leq 2.5V$	
Load High	$\leq 50mA$	
Output	A, B, 0	

Pin assignment TTL, HTL

Pin	Cable color	Assignment
Pin 1	pink	B inv.
Pin 2	blue	UB Sense
Pin 3	red	N (zero impulse)
Pin 4	black	N inv. (zero impulse inv.)
Pin 5	brown	A
Pin 6	green	A inv.
Pin 7	-	-
Pin 8	gray	B
Pin 9	-	-
Pin 10	white/green	GND
Pin 11	white	GND Sense
Pin 12	brown/green	UB

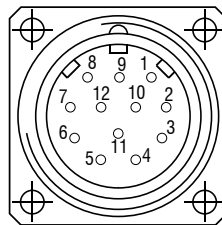

Pin 2 and Pin 12 are internally connected as well as Pin 11 and 10. For cable length >10m twisted pair wires are required.

Connection assignment E, E830

Cable color	Assignment
white	0V
brown	+UB
green	A
-	\bar{A}
yellow	B
-	\bar{B}
gray	0

Connection assignment TTL01

Cable color	Assignment
brown	0V
gray	+UB
white	A
green	B
yellow	0

Connection assignment TTL02

Cable color	Assignment
red	+UB
black	0V
brown	A
black	\bar{A}
orange	B
black	\bar{B}
yellow	0
black	n.c.

High performance sensors made by Micro-Epsilon



Sensors and systems for displacement and position



Sensors and measurement devices for non-contact temperature measurement



2D/3D profile sensors (laser scanner)



Optical micrometers, fiber optic sensors and fiber optics



Color recognition sensors, LED analysers and color inline spectrometer



Measurement and inspection systems